

GHOLOGRAPHIC COMPANY

Jhawar Kunj, Near Bajrang Dal Mill,
Kotri, Kota, Rajasthan, India – 324007

Email: gholographics@mail.com;

www.genuineholographics.com

Tel : +91 – 744 – 3295660;

Fax : + 91 – 744 -2366743

Mobile : +91- 9314235320 ; 9339224239

GHOLOGRAPHIC COMPANY

Jhawar Kunj, Near Bajrang Dal Mill, Kotri, Kota, Rajasthan, India – 324007

Email: gholographics@mail.com; www.genuineholographics.com

Company Profile

Gholographic Company , headquartered in India, has its own facilities for R&D, Manufacturing, Sales and Marketing. It has got Excellent Customer Support. Management team comprises of highly qualified and experienced individuals with diverse but coherent background; from business administration to cutting edge technology. All the strategic decisions are taken collectively under the dynamic leadership of our Managing Director.

It is a Business-to-Business company that specializes in Optics, Mechanical Mounts, Optical Software(ZEMAX, LASCAD, TFCal) and supply of different kind of holograms. We have evolved from the basic of R&D to marketing with progressive units of manufacturing and exports,a complete global provider.

We Provides Training and Consultancy on Desiging of Optical System, suggest best optical compenent for Research and Industry use

About Us

"We are your one-stop total solution for Science and Technology"

We can act as a virtual employee to businesses in need of optical design services for product designs that utilize optics of some sort. We can also perform analysis or tolerancing of existing designs. We utilize our education and experience as well as a variety of design tools to design superior optics and optical systems.

Look to Gholographic Company to develop custom software related to optics, imaging, or highly complex or numeric applications. We have much experience developing applications for stand-alone or for driving equipment. Our software is commercial quality and we have many applications that have been running in the field for many years without incident.

As Researcher, Scientist or Technician in the field of optics or light imaging, look to Gholographic Company for consultation on any aspect of optics that you need. Chances are, we have direct experience, have familiarity with, know an expert in the area, or can apply our closely related skills and knowledge to the task to get it done.

Not only in Light or Optics but we have expertise in Solar, Bio-Medical, Holography etc.

If you looking for any Training , Consultation and any type of support (such as making prototype) provide us chance to serve you best.



GHOLOGRAPHIC COMPANY

Jhawar Kunj, Near Bajrang Dal Mill, Kotri, Kota, Rajasthan, India – 324007



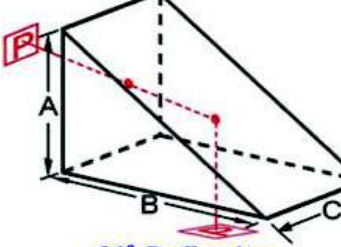
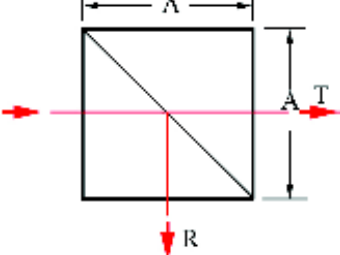
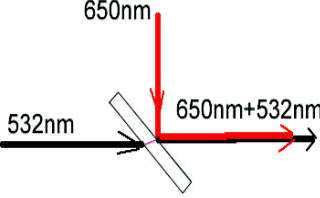

Email: gholographics@mail.com; www.genuineholographics.com

Gholographic Company : Products

Optics

		 <p style="text-align: center;"><i>90° Deflection</i></p>
Lenses	Aspheric Lens	Prism
		
Beam Splitter	Beam Combiner	

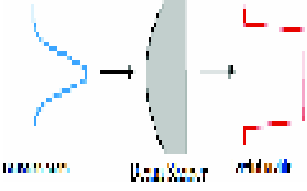
Optical Component



		
Beam Expander	Ftheta Scanning Lens	Telecentric Scanning Lens
		
Beam Shaper	Scanning Mirror	Protective Window

GHOLOGRAPHIC COMPANY

Jhawar Kunj, Near Bajrang Dal Mill, Kotri, Kota, Rajasthan, India – 324007

Email: gholographics@mail.com; www.genuineholographics.com

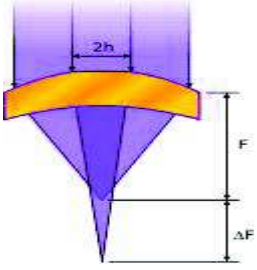
IR Optics

		
IR Camera Lens	Deep Focus Lens	Laser Goggles

Optical Software

		
ZEMAX	LASCAD	TFCalc



Services

		
Design Consultancy	Training	Design Books

Holography Products

		
Holographic Plate	Developer	Holography Kit

Instruments

	
Michelson Interferometer	Handheld Refractometer

GHOLOGRAPHIC COMPANY

Jhawar Kunj, Near Bajrang Dal Mill, Kotri, Kota, Rajasthan, India – 324007

Email: golographics@mail.com; www.genuineholographics.com

Spherical Lens

A **lens** is an optical device with perfect or approximate axial symmetry which transmits and refracts light, converging or diverging the beam. A simple lens consists of a single optical element. Lenses are typically made of glass or transparent plastic.

A lens is *biconvex* (or *double convex*, or just *convex*) if both surfaces are convex. If both surfaces have the same radius of curvature, the lens is *equiconvex*. A lens with two concave surfaces is *biconcave* (or just *concave*). If one of the surfaces is flat, the lens is *plano-convex* or *plano-concave* depending on the curvature of the other surface. A lens with one convex and one concave side is *convex-concave* or *meniscus*. It is this type of lens that is most commonly used in corrective lenses.

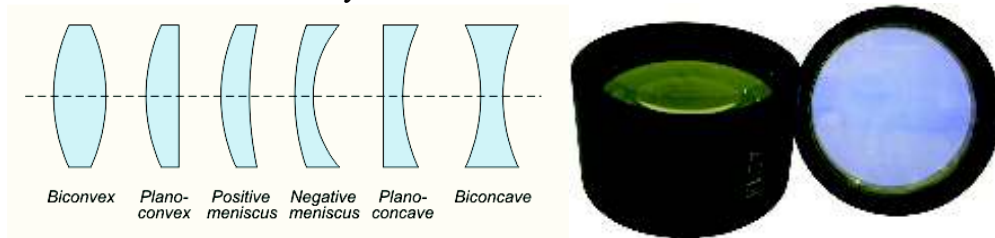

Specifications

Material: Zinc Selenide
 Design Wavelength: 10.6um
 Design Index: 2.4028@10.6um
 Diameter Tolerance: +0.0 / -0.1mm
 Paraxial Focal Length: $\pm 2\%$
 Centration: <3 arc minutes
 Clear Aperture: >80%
 Surface Figure: $\lambda/2@632.8\text{nm}$
 Surface Quality: 20/10 scratch and dig
 Protective Bevel

ZnSe Plano-Convex Lenses

Part Number	Dia (inch)	EFL (inch)
ZN0720	0.75"	2.0"
ZN0725	0.75"	2.5"
ZN1015	1.0"	1.5"
ZN1020	1.0"	2.0"
ZN1025	1.0"	2.5"
ZN1030	1.0"	3.0"
ZN1525	1.5"	2.5"
ZN1530	1.5"	3.0"
ZN1550	1.5"	5.0"
ZN20100	2.0"	10.0"

Custom made is available upon request

GHOLOGRAPHIC COMPANY

Jhawar Kunj, Near Bajrang Dal Mill, Kotri, Kota, Rajasthan, India – 324007

Email: gholographics@mail.com; www.genuineholographics.com

Aspheric Lens

An **aspheric lens** or **asphere** is a lens whose surfaces have a profile that is neither a portion of a sphere nor of a circular cylinder.

A single aspheric lens can often replace a much more complex multi-lens system. The resulting device is smaller and lighter, and possibly cheaper than the multi-lens design.

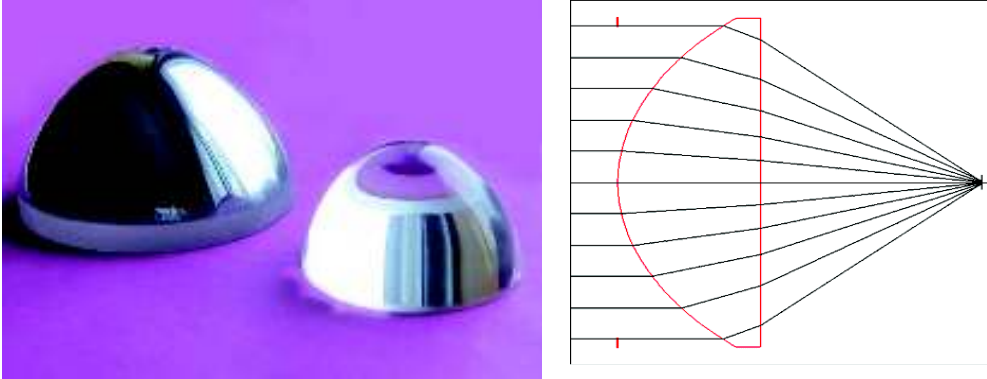

Small glass or plastic aspheric lenses can be made by molding, which allows cheap mass production. Due to their low cost and good performance, molded aspheres are commonly used in inexpensive consumer cameras, camera phones, and CD players.

GHOLOGRAPHIC COMPANY

Jhawar Kunj, Near Bajrang Dal Mill, Kotri, Kota, Rajasthan, India – 324007

Email: gholographics@mail.com; www.genuineholographics.com

Prisms

There are many types of prism, each having a particular geometry to achieve the desired reflections necessary to perform a specific imaging task. Reflecting prisms may invert, rotate, deviate or displace a beam. Dispersing prisms produce spectral separation for spectroscopic applications or for tuning a laser output.

We provide many kinds of high precision prisms, including Penta Prism, Beamsplitter Penta Prism, Right Angle Prism, and Corner Cube. Our micro Penta Prism and Right Angle Prism are widely used in optical communication, such as optical switches. Dove Prism and Roof Prism are also available upon request.



Specifications

Materials	BK 7, fine annealed
Surface Flatness	1/4
Angle	45°, 90°± 3' or ± 30"
Clear Aperture Diameter	90%
Surface Quality	60-40 scratch and dig

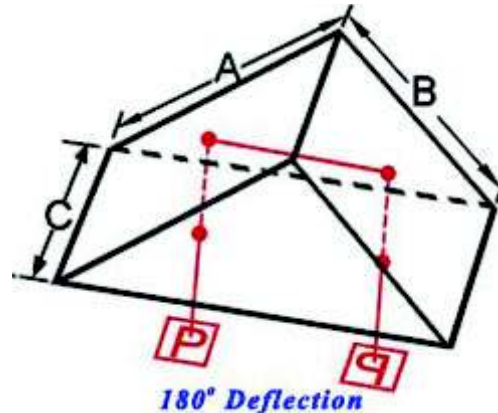
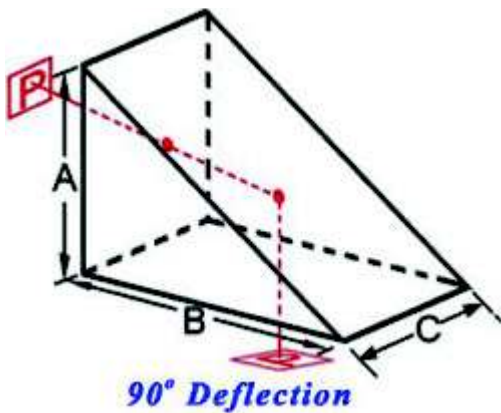

Dimension (mm)	Part No.	
	± 3'	± 30"
A=B=C		
5.0	WCL-030104	WCL-030104A
10.0	WCL-030105	WCL-030105A
12.7	WCL-030101	WCL-030101A
20.0	WCL-030106	WCL-030106A
25.4	WCL-030102	WCL-030102A
30.0	WCL-030107	WCL-030107A
40.0	WCL-030108	WCL-030108A
50.8	WCL-030103	WCL-030103A

GHOLOGRAPHIC COMPANY

Jhawar Kunj, Near Bajrang Dal Mill, Kotri, Kota, Rajasthan, India – 324007

Email: golographics@mail.com; www.genuineholographics.com

BEAMSPLITTER ...

Non-Polarizing Cube Beamsplitter

Non-polarizing Cube Beamsplitter consists of a pair of precision high tolerance right angle prisms cemented together with a metallic-dielectric coating on the hypotenuse of one of the prisms. The low polarization dependence of the metallic–dielectric coating allows the transmission and reflection for S and P-polarization states to be within 5% of each other. They will not change the state of polarization of the incident beam.

Specifications	
Dimension Tolerance	±0.2mm
Flatness	$\lambda/4@632.8\text{nm}$
Surface Quality	60-40 scratch and dig
Beam Deviation	<3 arc minutes
Transmittance	45% ± 5%
Absorption	<10%
Polarization	6%

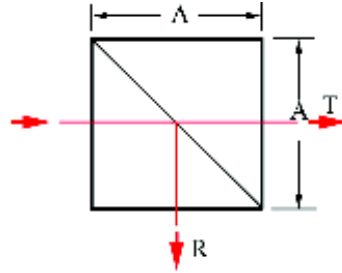

Part No.	Dimension (inch)	Wavelength (nm)
BSC-0.5-1064NP	0.5	1064
BSC-1-1064NP	1.0	1064
BSC9-905-5-NP	5(mm)	905

Polarizing Cube Beamsplitter

Polarizing Cube Beamsplitter split randomly polarized beams into two orthogonal, linearly, polarized components– S-polarized light is reflected at a 90deg angle while P-polarized light is transmitted. Each beamsplitter consists of a pair of precision high tolerance right angle prisms cemented together with a metallic-dielectric coating on the hypotenuse of one of the prisms.

Specifications	
Dimension Tolerance	±0.2mm
Flatness	$\lambda/4@632.8\text{nm}$
Surface Quality	60-40 scratch and dig
Beam Deviation	<3 arc minutes
Extinction ratio	>100:1
Principal Transmittance	$T_p > 95\%$ and $T_s < 1\%$
Principal Reflectance	$R_s > 99\%$ and $R_p < 5\%$

Part No.	Dimension (inch)	Wavelength (nm)
BSC-0.5-1064P	0.5	1064
BSC-1-1064P	1.0	1064

GHOLOGRAPHIC COMPANY

Jhawar Kunj, Near Bajrang Dal Mill, Kotri, Kota, Rajasthan, India – 324007

Email: golographics@mail.com; www.genuineholographics.com

Beam Combiner

Beam Combiners are ideal for applications where diode lasers are being used for system alignment. Designed for used at 45 degree, they transmit the long wavelength beam and align it with the 90 degree reflected diode beam.

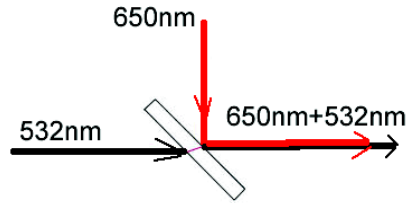

Beam Combiner for CO₂ Laser (wavelength 10.6um)

Average transmission > 99%@10.6um, Average reflection > 85%@650nm

Specifications

Diameter Tolerance	+0/-0.13mm
Thickness	±0.25mm
Side1	T>99%@10.6um,45AOI
Side2	T>99%@10.6um R>85%@650nm,45AOI
Flatness	λ/20 @10.6um

Part No.	Material	Diameter (inch)	Thickness (mm)
BCZ-0.5-2	ZnSe	0.5	2
BCZ-1.0-3	ZnSe	1.0	3
BCZ-1.5-3	ZnSe	1.5	3
BCZ-2-5	ZnSe	2.0	5

Beam Combiner for Nd:YAG Laser (wavelength 1064nm)

Average transmission > 99%@1064nm, Average reflection > 85%@650nm

Specifications

Diameter Tolerance	+0/-0.13mm
Thickness	±0.25mm
Side1	T>99%@1064nm,45AOI
Side2	T>99%@1064nm,R>85%@650nm,45AOI
Flatness	λ/2 @1064nm per 25mm dia

GHOLOGRAPHIC COMPANY

Jhawar Kunj, Near Bajrang Dal Mill, Kotri, Kota, Rajasthan, India – 324007

Email: golographics@mail.com; www.genuineholographics.com

Part No.	Material	Diameter (inch)	Thickness (mm)
BCBK-0.5-2	BK7	0.5	2
BCBK-0.75-3	BK7	0.75	3
BCBK-1.0-3	BK7	1.0	3
BCBK-1.5-3	BK7	1.5	3

Beam Combiner for Green Laser(532nm)

Part No.	Material	Diameter (inch)	Thickness (mm)
BCBK-1-3-532T650R	BK7	1	3

GHOLOGRAPHIC COMPANY

Jhawar Kunj, Near Bajrang Dal Mill, Kotri, Kota, Rajasthan, India – 324007

Email: gholographics@mail.com; www.genuineholographics.com

Beam Expander

Beam Expander is an Optical Component used in laser industry for expansion of beam. It is used for various applications such as laser scanning, interferometry, and remote sensing. We are able to provide expansion from 1 X to 50 X fixed magnification. We have newly developed Motorized Zoom Beam Expander; having expansion from 1 X to 8 X. we have beam expander from 266 nm to 10600 nm wavelength.

Advantage:

Input Beam is collimated or diverging; output from our beam expander is collimated with bigger beam diameter.

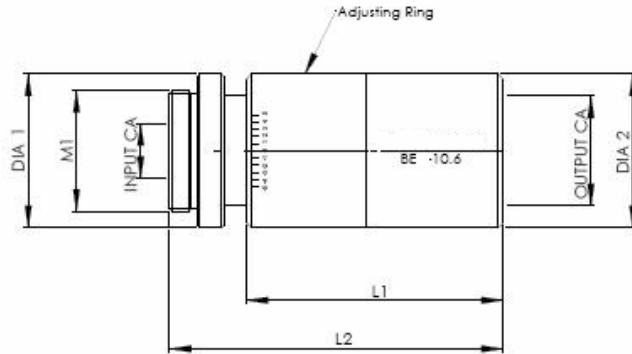

Model No.	Wavelength (nm)	Input CA (mm)	Output CA (mm)	Magnification X
BE-10.6-2X	10600	23	28	2
BE-10.6-4X	10600	23	28	4
BE-10.6-8X	10600	23	30	8
BE-1064-2X	1064	10	20	2
BE-1064-4X	1064	10	22	4
BE-1064-8X	1064	10	22	8
BE-633-2X	633	6	23	2
BE-633-4X	633	6	23	4
BE-633-8X	633	6	23	8
BE-532-2X	532	6	23	2
BE-532-4X	532	6	23	4
BE-532-8X	532	6	23	8
BE-405-2X	405	6	30	2
BE-405-5X	405	6	30	5

GHOLOGRAPHIC COMPANY

Jhawar Kunj, Near Bajrang Dal Mill, Kotri, Kota, Rajasthan, India – 324007

Email: golographics@mail.com; www.genuineholographics.com

BE-405-7X	405	6	30	7
BE-355-2X	355	7	24	2
BE-355-4X	355	8	28	4
BE-355-8X	355	8	28	8
BE-266-2X	266	8	24	2
BE-266-5X	266	10	24	5
BE-266-10X	266	6	24	10



Laser Energy Profile At Different Distance

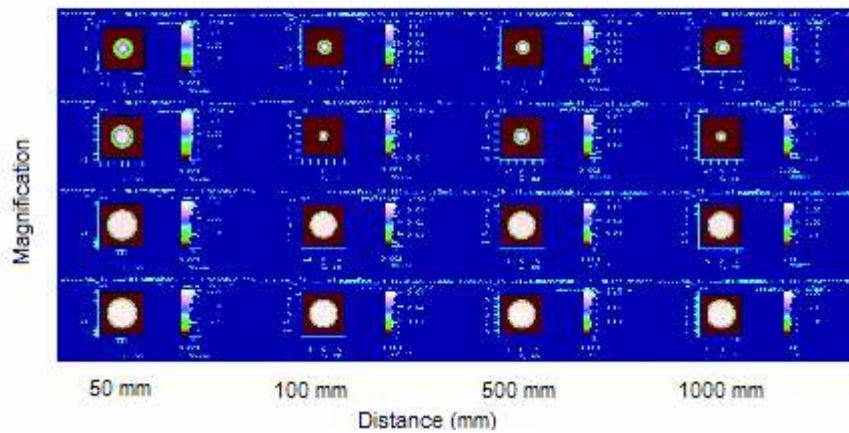

Motorized Zoom Beam Expander

Motorized Zoom Beam Expander is controlled by micro-motor drive system, in order to control the divergence of laser beam and to achieve continuous adjustment. This motorized system is composed of electro-mechanical components and a pair of meshing gear. Controlled board is another separated unit. This motorized beam expander will be connected with a PC, so as to remotely control. In addition, as the controllability on its motor revolutions, focusing adjustment becomes more accurate.

Our Motorized beam expander for 10.6um / 1064nm / 633nm/ 532nm / 355nm and customized expander from 1-8 X Magnification.

Model No.	Wavelength (nm)	Input CA (mm)	Output CA (mm)	Magnification X
BE-10.6-2-8X	10600	10	36	2X to 8 X
BE-1064-1-8X	1064	12	32	1X to 8X
BE-633-1-8X	532	12	32	1X to 8X

GHOLOGRAPHIC COMPANY

Jhawar Kunj, Near Bajrang Dal Mill, Kotri, Kota, Rajasthan, India – 324007

Email: golographics@mail.com; www.genuineholographics.com

BE-532-1-8X	532	12	32	1X to 8X
BE-355-1-8X	355	12	32	1X to 8X
BE-266-1-8X	266	12	32	1X to 8X

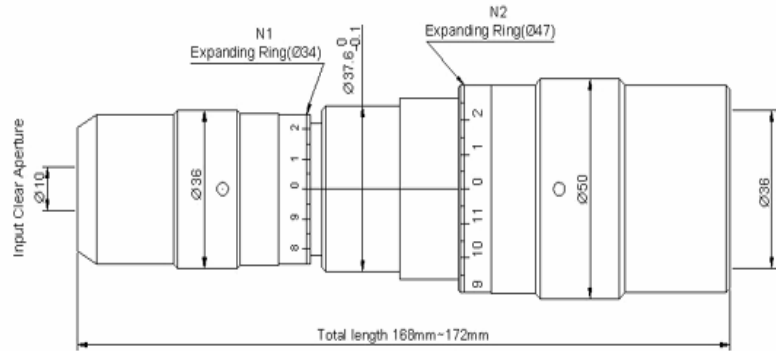
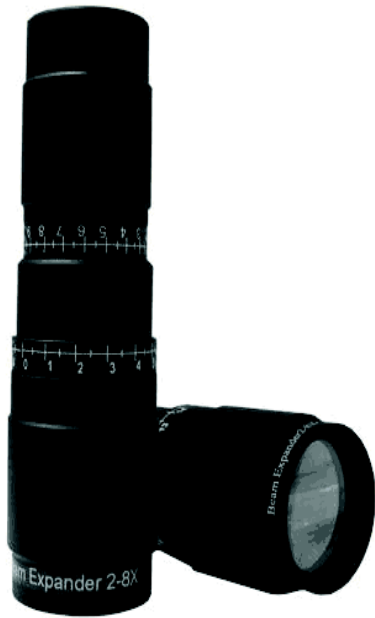

GHOLOGRAPHIC COMPANY

Jhawar Kunj, Near Bajrang Dal Mill, Kotri, Kota, Rajasthan, India – 324007

Email: gholographics@mail.com; www.genuineholographics.com

Beam Shaper

Beam Shaper is used in many applications where user want uniform beam in form of Top Hat profile instead of Gaussian beam. This is best optical component ever used to change profile. It is an afocal system which is demanding product in laser industry. We will provide Beam shaper from visible range to IR range.

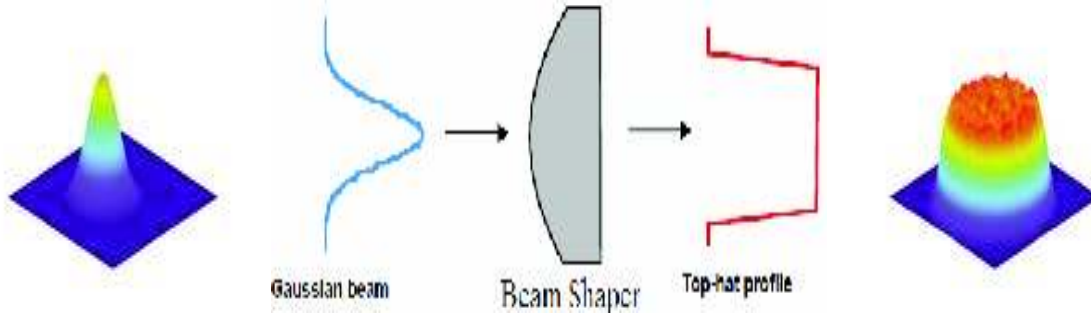

The design is based on transmissive model that can be used with maximum input beam size of 4.6mm and 6mm. Currently, we have available design from 266-1064 nm, 10.6um wavelength.

Beam Shaper with shorter working distance up to 200mm

Part no.	Wavelength	Applicable Input Beam Size (mm)	Output Beam Size (mm)	Max. outer Dia (mm)	Total Length (mm)	Working Distance (mm)
BS	1064/532/355/266	4.6-5	6	27	170.7	25-200

BS-W600 Series Beam Shaper

BS-W600 series of beam shaper is developed for longer working distance up to 600mm

Part no.	Wavelength(nm)	Applicable Input Beam Size (mm)	Output Beam Size (mm)	Max. outer Dia (mm)	Total Length (mm)	Working Distance (mm)
BS- W600	1064/532/355	5.8-6	5-5.5	30	175.53	100-600

BS-10.6

Part no.	Wavelength(um)	Applicable Input Beam Size (mm)	Output Beam Size (mm)	Max. outer Dia (mm)	Total Length (mm)	Working Distance (mm)
BS-10.6-3	9.4/10.6/11	3-4	3-4	28	109	25-100
BS-10.6-12	9.4/10.6/11	12	12	38	270	25-200

GHOLOGRAPHIC COMPANY

Jhawar Kunj, Near Bajrang Dal Mill, Kotri, Kota, Rajasthan, India – 324007

Email: golographics@mail.com; www.genuineholographics.com

Application Area :

Beam shaping is used in a number of sectors of scientific, engineering, and industrial research and development and has become an important component of laser-based applications such as

- **lithography**
- **materials processing**
- **isotope separation**
- **medical applications**
- **laser printing**
- **optical data storage**
- **laboratory research**
- **Optical character recognition (OCR)**
- **Night vision**
- **Bio-detection**
- **Flow cytometry**
- **Micromachining**

GHOLOGRAPHIC COMPANY

Jhawar Kunj, Near Bajrang Dal Mill, Kotri, Kota, Rajasthan, India – 324007

Email: gholographics@mail.com; www.genuineholographics.com

Ftheta Lenses

F-theta lenses used for laser marking/scanning/engraving application. scanning area is linear relationship between the input scan angle and the focal position on a flat plane. Since spot size is proportional to focal length; we can provide short focal length scanning Ftheta lenses. We use fused-silica material to provide better optical transmission than standard BK7 glass. By this user can operate with less laser power, extending laser lifetime, and also reduces heat build-up in the lens due to absorption, extending lens lifetime. We have scanning lens from 266 to 10600 nm wavelength.

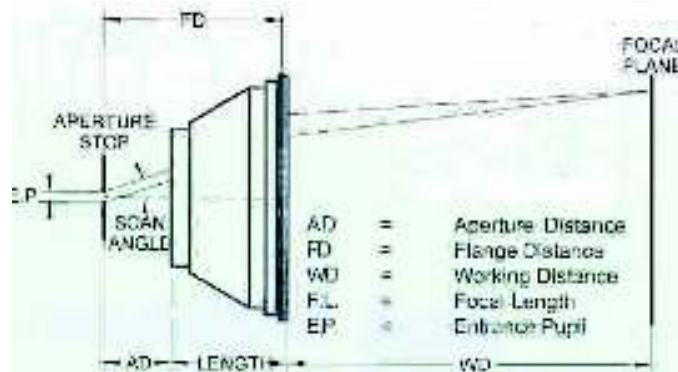

Model No.	Wavelength (nm)	Scan Area (mmxmm)	Input Beam (mm)	Focal Length (mm)	Working Distance (mm)
SL-10.6-35-60	10600	35 x 35	12	60	57.8
SL-10.6-70-122	10600	70 x 70	14	122	130
SL-10.6-210-300	10600	210 x 210	14	300	335
SL-1064-70-100	1064	70 x 70	14	100	100
SL-1064-140-210	1064	140 x 140	14	210	238
SL-1064-500-815	1064	500 x 500	24	815	925
SL-532-70-100	532	70 x 70	14	100	100
SL-532-150-254	532	150 x 150	10	254	280
SL-532-510-740	532	510 x 510	16	740	896
SL-355-60-100	355	60 x 60	6	100	130
SL-355-155-250	355	155 x 155	10	250	300
SL-266-70-100	266	70 x 70	5	100	130
SL-266-100-160	266	100 x 100	5	160	198

GHOLOGRAPHIC COMPANY

Jhawar Kunj, Near Bajrang Dal Mill, Kotri, Kota, Rajasthan, India – 324007

Email: golographics@mail.com; www.genuineholographics.com

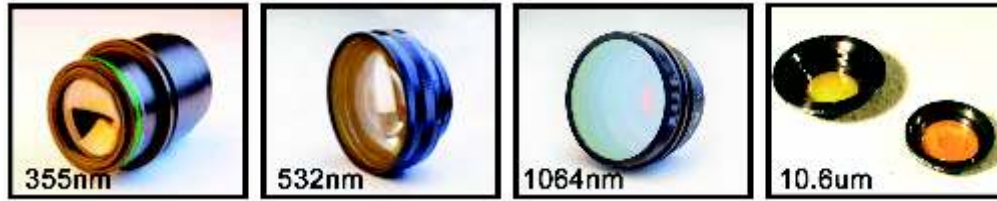

Telecentric Scanning Lens

Telecentric scanning lenses, similar to Ftheta Lens only difference is that Telecentric maintain normal incidence angle of the beam to the work piece. This ensures that position errors and image distortions are minimized over the entire scan range. Telecentric scanning lenses offer greater depth of field and smaller spot sizes when marking objects for laser material processing.

Having a greater depth of field and smaller spot size are important for precision laser micro-machining processes where there is a need to produce fine spot sizes so as to control the width of a laser mark, scribe or drilled hole while maintaining precise placement over a relatively large field. The ability to accomplish this is sometimes affected by just minimal warping of a wafer or solar panel.

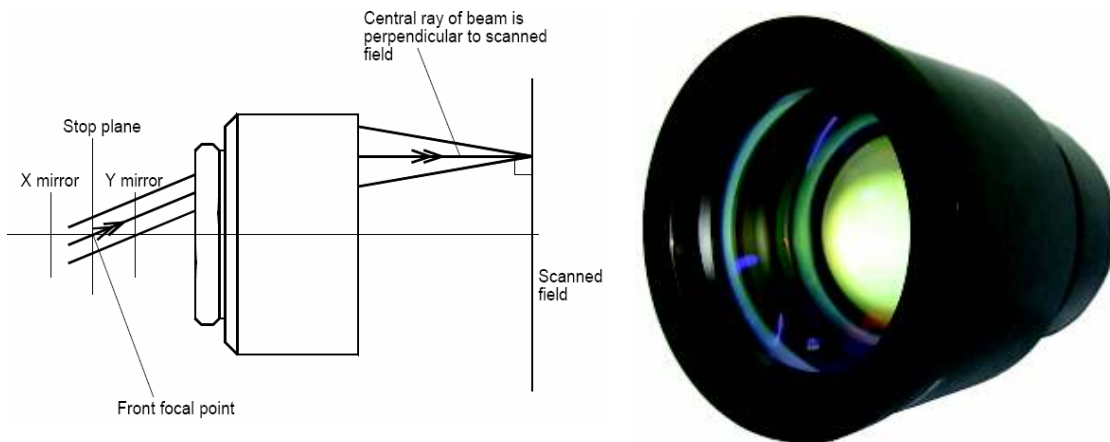

Model No.	Wavelength (nm)	Scan Area (mmxmm)	Input Beam (mm)	Focal Length (mm)	Working Distance (mm)
TSL-10.6-50-100	10600	50 x 50	25	100	106
TSL-1064-20- 56	1064	20 x 20	10	56	60
TSL-1064-70-115	1064	70 x 70	12	115	137
TSL-1064-126-216	1064	126 x 126	15	216	343
TSL-633- 77-156	633	77 x 77	10	156	221
TSL-532-60-100	532	60 x 60	12	100	128
TSL-532-140-200	532	140 x 140	10	200	216
TSL-355-60-100	355	60 x 60	6	100	143
TSL-266-50-100	266	50 x 50	5	100	135

GHOLOGRAPHIC COMPANY

Jhawar Kunj, Near Bajrang Dal Mill, Kotri, Kota, Rajasthan, India – 324007

Email: golographics@mail.com; www.genuineholographics.com

Scanning Mirror

Scanning mirrors are used for high speed two-axis laser scanner system. The dimension of each mirror have been calculated to allow for scanning of a laser beam at up to 25 degrees off-axis. The mirrors have high reflectivity and so may be safe at high powers.

Specification:

- Flatness: $\lambda/4$ @633nm, Scratch/Dig: 40/20, Reflective coating: 1-sided
- Silicon, Gold or Silver coating for CO₂ Laser (10.6um)
- Si/BK7/FS, Dielectric or Silver coating for Nd:YAG Laser (1064nm/650nm/532nm)
- Si/BK7/FS, Dielectric coating for Green & Visible Laser (650nm/355nm)
- Mounted scanning mirror are available upon request.
- Wavelength: 10.6um/1064nm/532nm/355nm

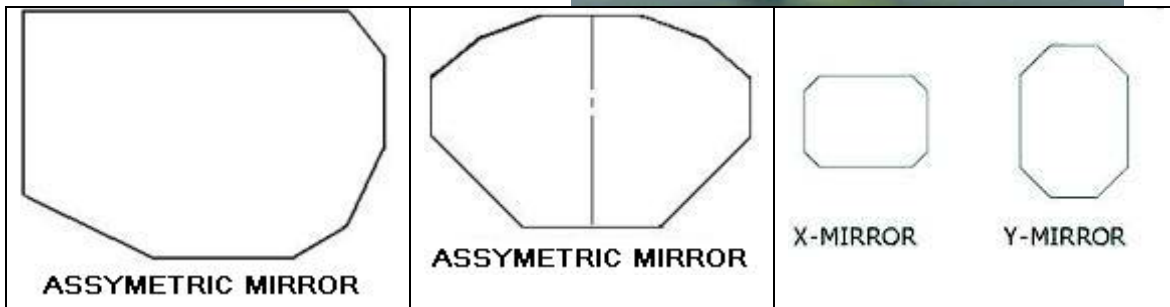

Model No.	Dimension l x b x h (mm)	Substrate	Beam Size (mm)
SCM-12.6x15x1.7	12.6x15x1.7	Si/BK7/FS	8
SCM-16.4x28x1.7	16.4x28x1.7	Si/BK7/FS	10
SCM-21.3x38.9x3.2	21.3x38.9x3.2	Si/BK7/FS	12
SCM-24.8x39.4x3.2	24.8x39.4x3.2	Si/BK7/FS	15
SCM-32x39x2	32x39x2	Si/BK7/FS	20
SCM-35x45x2	35x45x2	Si/BK7/FS	25

GHOLOGRAPHIC COMPANY

Jhawar Kunj, Near Bajrang Dal Mill, Kotri, Kota, Rajasthan, India – 324007

Email: golographics@mail.com; www.genuineholographics.com

Protective Window

Windows of special sizes and materials are available upon request.

Windows are applied to isolate different physical environments while allowing light to pass through. When selecting windows, please consider the material, transmission, scattering, wave front distortion, parallelism and resistance to certain environment. We offer all kinds of windows, which are made from different materials.



Single layer, multiplayer anti-reflecting coatings on optical windows are also available upon request.

Specifications	
Diameter Tolerance:	+0.0, -0.2 mm
Thickness Tolerance:	±0.2mm
Clear Aperture:	>80%
Parallelism:	<3 arc min
Surface Quality:	40-20 scratch and dig
Flatness	$\lambda/2$ @632.8nm per 25mmDia

Protection Window for 9.4/10.6 μm

Model No.	Material	Ø (mm/inch)	Thk. (mm)
WGE-75-2.5	Ge	75	2.5
WGE-90-2.5	Ge	90	2.5
WZ-0.5-2	ZnSe	0.5"	2.0
WZ-0.75-3	ZnSe	0.75"	3.0
WZ-1-3	ZnSe	1.0"	3.0
WZ-1.1-3	ZnSe	1.1"	3.0
WZ-1.5-3	ZnSe	1.5"	3.0
WZ-1.5-5	ZnSe	1.5"	5.0
WGA-60-1	GaAs	60	1.0
WGA-109.5-4	GaAs	109.5	4.0

GHOLOGRAPHIC COMPANY

Jhawar Kunj, Near Bajrang Dal Mill, Kotri, Kota, Rajasthan, India – 324007

Email: golographics@mail.com; www.genuineholographics.com

Protection Window for 1064/532 nm

Model No.	Material	Ø (mm/inch)	Thk. (mm)
WFS-1-3	Fused Silicon	1"	3
WFS-1.5-5	Fused Silicon	1.5"	5
WFS-15-2	Fused Silicon	15	2
WFS-18-3	Fused Silicon	18	3
WFS-20-2	Fused Silicon	20	2
WFS-36-2	Fused Silicon	36	2

GHOLOGRAPHIC COMPANY

Jhawar Kunj, Near Bajrang Dal Mill, Kotri, Kota, Rajasthan, India – 324007

Email: gholographics@mail.com; www.genuineholographics.com

INFRARED CAMERA LENSES

Gholographic Company can offers variety of Infrared Lens for defense, FLIR system, and Surveillance application.

Our premier range of IR lens for cooled and uncooled camera system includes:

- SWIR Lens (1-5um)
- MWIR Lens (2-5um)
- MWIR Lens (3-5um)
- LWIR Lens (8-12um)



Besides above, we also offers high end sophisticated lens includes:

- IRDB Lens Double Band (4.3um--5.4um,7.8-8.8um)
- IR2FV Lens Double Field View
- IR Zoom Lens
- IR Athermal Lens
- Motorized & Computerized

SWIR Lens (1-5um)

Part No.	Focal Length (mm)	F/# (mm)	Wavelength(um)	Focus Type
<u>IRS0252015.36</u>	25mm	2	1um--5um	Manually adjustable

MWIR Lens (2-5um)

Part No.	Focal Length (mm)	F/# (mm)	Wavelength(um)	Focus Type
<u>IRM050201024</u>	50mm	2	2um--5um	Manually adjustable

MWIR Lens (3-5um)

Part No.	Focal Length (mm)	F/# (mm)	Wavelength(um)	Focus Type
<u>IRM1X</u>	45mm	3.3(NA:0.15)	3um--5um	Manually adjustable
<u>IRM05020320</u>	50mm	2	3um--5um	Manually adjustable
<u>IRM5X</u>	55mm	2.0-4.0(NA:0.125-0.25)	3um--5um	Manually adjustable
<u>IRM10020320</u>	100mm	2	3um--5um	Manually adjustable

LWIR Lens (8-12um)

Part No.	Focal Length (mm)	F/# (mm)	Wavelength(um)	Focus Type
<u>IR00920160</u>	9mm	2	8um--12um	Manually adjustable

GHOLOGRAPHIC COMPANY

Jhawar Kunj, Near Bajrang Dal Mill, Kotri, Kota, Rajasthan, India – 324007

Email: gholographics@mail.com; www.genuineholographics.com

<u>IR01020160</u>	10mm	2	8um--12um	Manually adjustable
<u>IR02510384G</u>	25mm	1	8um--12um	Manually adjustable
<u>IR02909160</u>	29mm	0.9	8um--12um	Manually adjustable
<u>IR03510160</u>	35mm	1	8um--12um	Manually adjustable
<u>IR03510384</u>	35mm	1	8um--12um	Manually adjustable
<u>IR04008320</u>	40mm	0.8	8um--12um	Manually adjustable
<u>IR05008320</u>	50mm	0.8	8um--12um	Manually adjustable
<u>IR07510320</u>	75mm	1	8um--12um	Manually adjustable
<u>IR10010320</u>	100mm	1	8um--12um	Manually adjustable
<u>IR10020640</u>	100mm	2	8um--12um	Manually adjustable
<u>IR12510320</u>	125mm	1	8um--12um	Manually adjustable
<u>IR15010320</u>	150mm	1	8um--12um	Manually adjustable

IRDB Lens Double Band (4.3um--5.4um,7.8-8.8um)

Part No.	Focal Length (mm)	F/# (mm)	Wavelength(um)	Focus Type
<u>IRDB01520384</u>	15mm	2	4.3um--5.4um,7.8-8.8um	Manually adjustable
<u>IRDB02020384</u>	20mm	2	4.3um--5.4um,7.8-8.8um	Manually adjustable
<u>IRDB02520384</u>	25mm	2	4.3um--5.4um,7.8-8.8um	Manually adjustable
<u>IRDB10020384</u>	100mm	2	4.3um--5.4um,7.8-8.8um	Manually adjustable

IR2FV Lens Double Field View

Part No.	Focal Length (mm)	F/# (mm)	Wavelength(um)	Focus Type
<u>IRM2FV15050</u>	150mm/50mm	4	3.6um--4.9um	Manually adjustable
<u>IR2FV18060</u>	180mm/60mm	1.4	8um--12um	Manually adjustable

IR Zoom Lens

Part No.	Focal Length (mm)	F/# (mm)	Wavelength(um)	Focus Type
<u>IRZ10010320</u>	33mm-100mm	1	8um--12um	Manually adjustable

IR Athermal Lens

Part No.	Focal Length (mm)	F/# (mm)	Wavelength(um)	Focus Type
<u>IRA02510648</u>	25mm	1	8um--12um	Motor
<u>IRA05010648</u>	50mm	1	8um--12um	Motor
<u>IRA07510648</u>	75mm	1	8um--12um	Motor
<u>IRA10010648</u>	100mm	1	8um--12um	Motor

GHOLOGRAPHIC COMPANY

Jhawar Kunj, Near Bajrang Dal Mill, Kotri, Kota, Rajasthan, India – 324007

Email: gholographics@mail.com; www.genuineholographics.com

Motorized & Computerized

We offers motorized IR lens as well as computerized IR lenses. Motorized features will make operation easier and at other cases, motorized features are must for active athermal application. Our typical voltage applied on motor is 5V, 12 V subject to lens size and motor size. The motor is with reliable quality and can work under hash environment from -30 degree to +70 degree. Any lower or higher temperature will need special motor which is also available.

Computerized IR Lens has smart feature that is to move lens by software through central computer. While you are viewing IR image in the screen in the central room, you can zoom or move the lens to see more clear detail or larger field from computer or console. Our connection is RS232 or USB type. Software upgrade support is available over the time.



GHOLOGRAPHIC COMPANY

Jhawar Kunj, Near Bajrang Dal Mill, Kotri, Kota, Rajasthan, India – 324007

Email: gholographics@mail.com; www.genuineholographics.com

Deep-Focus Lens

Deep-Focus lenses are designed for CO₂/ YAG laser cutting and many other applications. Deep-Focus lenses also allow much thicker materials to be cut at a given laser power.

How Does Deep-Focus Lenses Work?

A Deep-Focus lens has two focal points. The inner portion of a laser beam is intercepted by a section of the lens, of diameter '2h', which has a longer focal length (FL) than the outer part of the lens. The 'basic focal length' is F. The difference in FL is ΔF .

This results in high energy density and increased localized temperature at both the upper and lower foci.

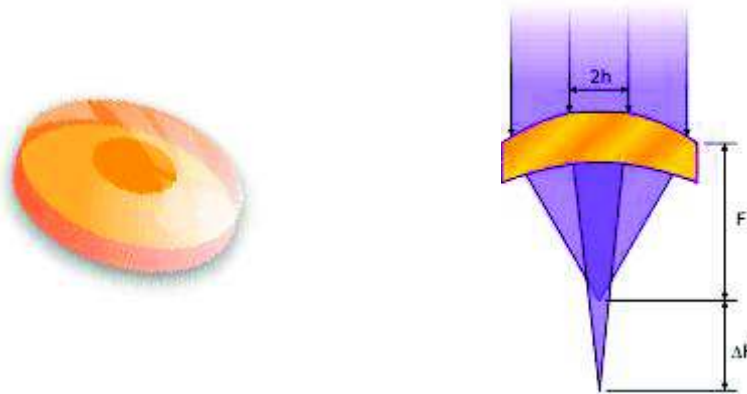

Part No.	Material	Diameter (inch)	FL (inch)	ET
LZDF-1-2.5/3.5-ET4	ZnSe	1	2.5/3.5	4
LZDF-1.1-5/7.5	ZnSe	1.1	5/7.5	4
LZDF-1.5-5/7.5/10	ZnSe	1.5	5/7.5/10	6/7.4
LZDF-2-5/7.5/10	ZnSe	2	5/7.5/10	8/9.6

GHOLOGRAPHIC COMPANY

Jhawar Kunj, Near Bajrang Dal Mill, Kotri, Kota, Rajasthan, India – 324007

Email: gholographics@mail.com; www.genuineholographics.com

LASER GOGGLES:

Gholographic Company can provide stock as well as custom made “Laser Goggles” in various size within broad wavelength band from UV to IR Range. These safety eye wear can use in various industry such as Hospital, laser industry, research lab , laser operation as well operation for skin protection.

Our eye is very sensitive part of body. One cannot judge the effect of laser in his eyes within few month but stray light of laser will slowly slowly damage Retina. Our Laser goggles help in preventing stray light to enter our eyes.

Near-IR lasers, 760 - 1400 nm, present special hazards. These wavelengths are in the retinal hazard region, but they are invisible. Thus stray beams and reflections cannot be seen, and might be detected only as the result of an injury. Many serious retinal injuries have been caused by accidental exposure to near-IR laser beams.

What factors should be considered when selecting specific eyewear?

1. Laser wavelength at which protection is afforded.
2. Optical density (OD) of the LSE for the wavelength being used. OD refers to the ability of a material to reduce laser energy of a specific wavelength to a safe level below the MPE. It can be expressed by the following formula:

$$OD = \log_{10}(E_i/E_t)$$

E_i = incident beam irradiance (W/cm²) for a "worse case exposure"

E_t = transmitted beam irradiance (MPE limit in W/cm²)

Example: OD of 4.0 allows 1/10,000 of the laser light energy to be transmitted.



GHOLOGRAPHIC COMPANY

Jhawar Kunj, Near Bajrang Dal Mill, Kotri, Kota, Rajasthan, India – 324007

Email: gholographics@mail.com; www.genuineholographics.com



OSLO – Optical Design Software

OSLO (Optics Software for Layout and Optimization) is a powerful optics design program. OSLO was the first software to demonstrate the serious optics and lens design could be carried out using desktop computers.

Application Industry:

IMAGING SYSTEMS

Photolithography
Optical Metrology
Laboratory Instruments
Optical Testing
Spectrographs
Astronomical Telescopes

LASER SYSTEMS

Fiber Couplers
Laser Focusing
Collimators
Scanners
Cavity Design
Beam Delivery

NONIMAGING OPTICS

Illumination Systems
Interferometers
Solar Collectors
Faceted Reflectors
Condensors
Light Concentrators

VISUAL SYSTEMS

Microscopes
Telescopes
Refractometers
Low Vision Aids
Endoscopes
Virtual Reality
Night Vision

Price List :

Permanent license plus 12 months of support	Fixed license	Network license
OSLO Premium Edition	\$3,500	\$4,000
OSLO Standard Edition	\$2,500	\$3,000
OSLO Light Edition	\$1,250	

OSLO's major features include:

- Lens and Material Databases
- Special Surface Data
- Zoom and Multiconfiguration
- Systems
- Arrays and Non-Sequential Groups
- Special Apertures
- Tolerance and Element Data
- Polarization and Thin Film
- Coatings
- Ray tracing
- Diffraction and Partial Coherence
- Optimization Methods
- Ghost Images
- Narcissus Analysis
- Polarization Ray Trace
- Non-Sequential Ray Trace
- Gaussian Beam Analysis
- Partial Coherence Analysis
- Fiber Coupling
- OSLO imports files from the following programs: CodeV, GENII, Sigma, Zemax
- OSLO files export to CAD programs
- Append data files from

GHOLOGRAPHIC COMPANY

Jhawar Kunj, Near Bajrang Dal Mill, Kotri, Kota, Rajasthan, India – 324007

Email: golographics@mail.com; www.genuineholographics.com

- Tolerance Analysis
- Lasers, Fibers, and Gaussian Beams
- Illumination Analysis
- Perfect Lenses and Eikonals
- Vignetting Analysis
- Footprint Analysis
- Spot Diagram
- Wavefront Analysis
- Point Spread Function
- Modulation Transfer Function
- Energy Distribution
- Monte Carlo Analysis

commercial interferometers to any surface for advanced simulation and tolerancing.

- Support for Radiant Imaging data files
- Fast Optimization
- Standard Surface
- Cylindrical Surface
- Lenslet Array
- Diffractive Surfaces
- User Defined Surfaces
- Interferogram Files
- Aspheric Surfaces
- Gradient Index Surfaces

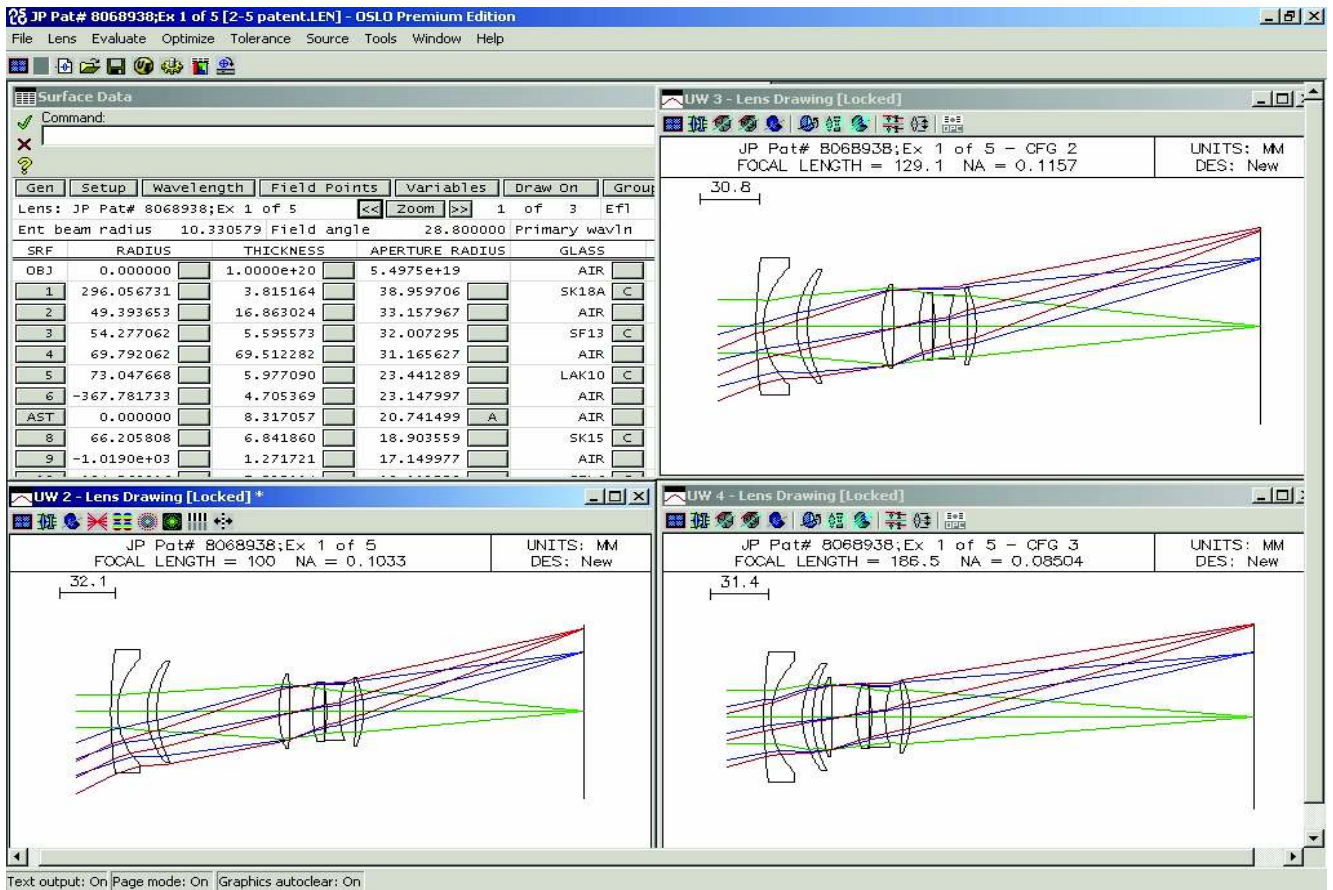

GHOLOGRAPHIC COMPANY

Jhawar Kunj, Near Bajrang Dal Mill, Kotri, Kota, Rajasthan, India – 324007

Email: gholographics@mail.com; www.genuineholographics.com



OPTO MECHANICAL SOFTWARE FOR ILLUMINATION ANALYSIS & OPTIMIZATION

TracePro is award-winning software of Lambda Research Corporation, USA for **illumination design**, illumination analysis, LCD backlight design, Display, OLED, Scattering analysis, optical system analysis, stray light analysis, baffle design for stray light suppression in telescopes and other optical systems, and analysis of many other types of optical systems and illumination systems.

Benefits of TracePro Software:

- 3-D CAD User Interface.
- TracePro is seamlessly interoperable with lens design software such as OSLO®, ZEMAX® and CODE V® and with CAD software such as SolidWorks®, AutoCAD®, Pro/E® and CATIA® via a series of file [translators](#).
- TracePro, renowned in the scientific community for the accuracy of its simulations
- Optimizing Lighting and Illumination Systems
- TracePro is a non-sequential optimization module that uses TracePro’s DDE interface and Scheme macro language to transfer information back and forth between the utility and TracePro.
- User has complete control of 7 different operand types, flux, irradiance, intensity, CIE (x,y) CIE (u,v), Irradiance Profile and Candela profile.
- Bitmap Converter acts to project the “light” from an arbitrary planar scene(BMP, JPEG, GIF, or PNG file) into an optical system.

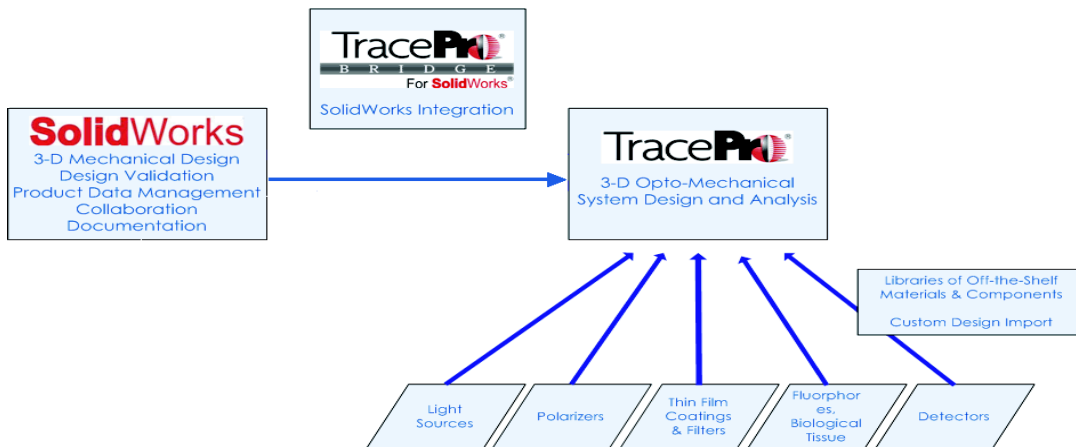

GHOLOGRAPHIC COMPANY

Jhawar Kunj, Near Bajrang Dal Mill, Kotri, Kota, Rajasthan, India – 324007

Email: gholographics@mail.com; www.genuineholographics.com

APPLICATION INDUSTRY

- Arc Lamps
- Lightpipes
- Ghost Analysis
- Narcissus Analysis
- LED Systems
- Laser Diode Systems
- IR Imaging
- IR Detection Systems
- Lithography
- Medical Applications
- Fiber Optic Design
- Unusual Optics and Lenslet Arrays
- Beam Splitter and Prism Systems
- Illumination and Display Systems
- Projection Systems
- Life Sciences
- LCD Projection
- Stray Light Analysis
- Conventional Optics

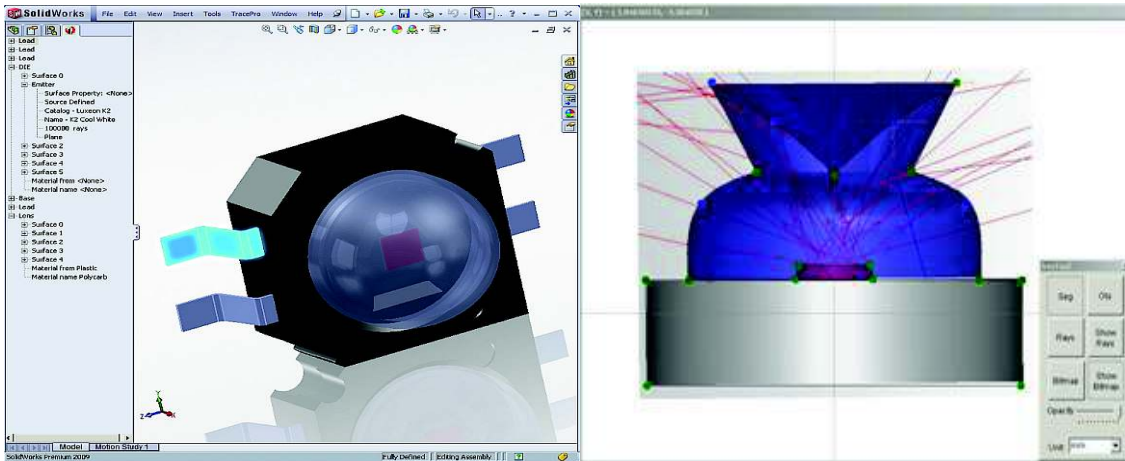

Optimizing Lighting and Illumination Systems

[TracePro](#) is a comprehensive, versatile software tool for modeling the propagation of light in imaging and non-imaging opto-mechanical systems.

TracePro help in modeling Modeling lighting and illumination systems is a complex task that is facilitated with automated algorithms that systematically vary the model's geometric parameters to achieve optimum illumination distributions. Trace Pro do best and provide

To define a merit function the user has complete control of 7 different operand types, flux, irradiance, intensity, CIE (x,y) CIE (u,v), Irradiance Profile and Candela profile.

GHOLOGRAPHIC COMPANY

Jhawar Kunj, Near Bajrang Dal Mill, Kotri, Kota, Rajasthan, India – 324007

Email: gholographics@mail.com; www.genuineholographics.com

LASCAD - Laser Cavity Analysis and Design

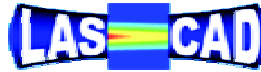

LASCAD has become an industry-leading software package for LASER Cavity Analysis and Design.

LASCAD provides a unique combination of simulation tools:

- **Thermal and Structural Finite Element Analysis (FEA)** of thermal effects in laser crystals,
- **ABCD Gaussian Beam Propagation** taking into account thermal lensing, gain guiding etc.,
- **Dynamic Analysis of Multimode and Q-switch operation (DMA)**,
- **3D Wave Optics Beam Propagation Code** including diffraction, gain saturation etc.

Integration of these modules into one program package makes LASCAD a versatile instrument to model laser cavities, and to solve the problems laser engineers are confronted with. LASCAD especially provides the following computational capabilities:

- Analysis of the 3-D nonlinear interaction of thermal and optical fields, commonly known as thermal lensing effect, which is one of the key problems in solid-state laser design,
- Computation of efficiency and power output,
- Modelling of multimode competition, beam profile, and beam quality,
- Computation of pulse shape and pulse energy for Q-switch operation,
- Numerical Eigenmode Analysis,
- Beam Propagation outside the laser cavity.

Based on a quantitative model of the multiphysics effects in laser cavities, LASCAD allows the laser engineer to control and compensate individual features of a resonator design prior to committing hardware.

GHOLOGRAPHIC COMPANY

Jhawar Kunj, Near Bajrang Dal Mill, Kotri, Kota, Rajasthan, India – 324007

Email: gholographics@mail.com; www.genuineholographics.com

ScreenShots of LASCAD

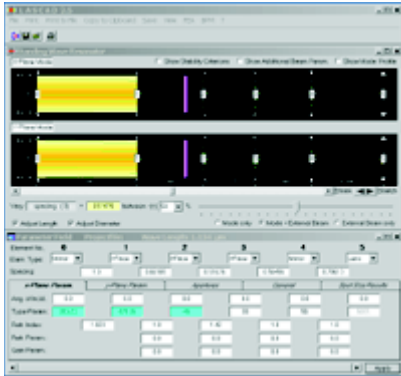

Graphical user interface of LASCAD

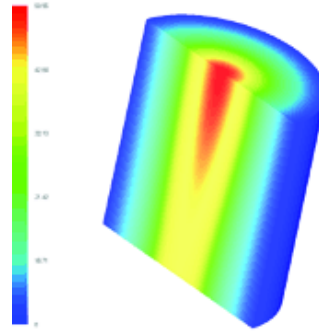

Temperature distribution in an end pumped

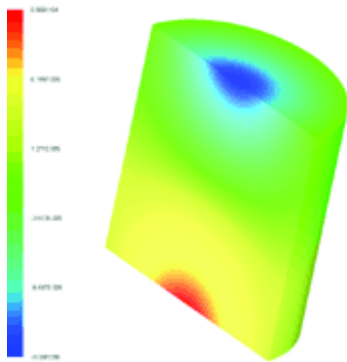

Deformation of an end pumped rod

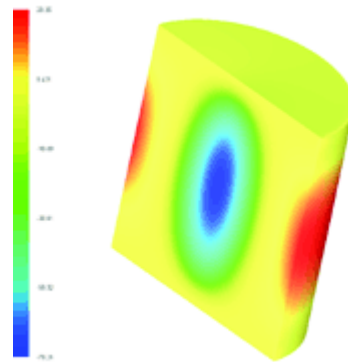

zz component of stress in an end pumped rod

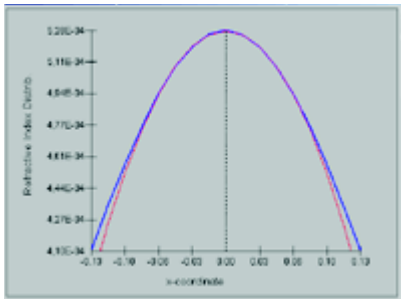

Parabolic fit of refractive index

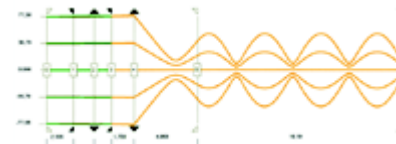

Coupling into a graded index fiber

GHOLOGRAPHIC COMPANY

Jhawar Kunj, Near Bajrang Dal Mill, Kotri, Kota, Rajasthan, India – 324007

Email: golographics@mail.com; www.genuineholographics.com

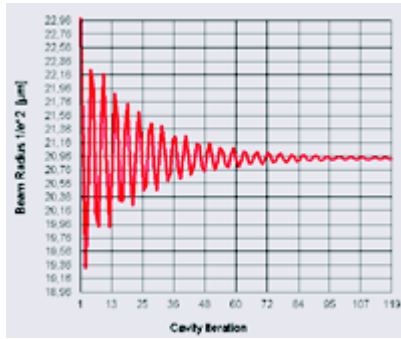

Convergence of beam radius with laser cavity iteration

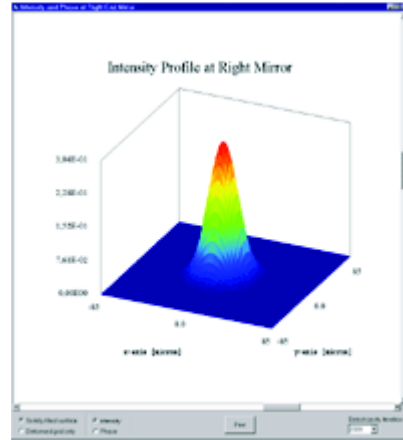

Intensity profile at outcoupling mirror

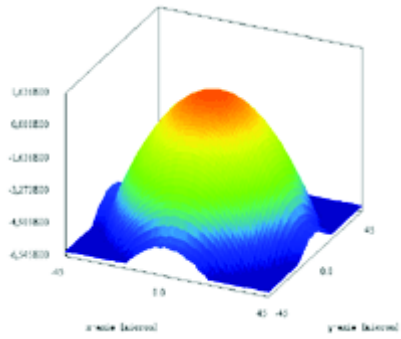

Phase profile at outcoupling mirror

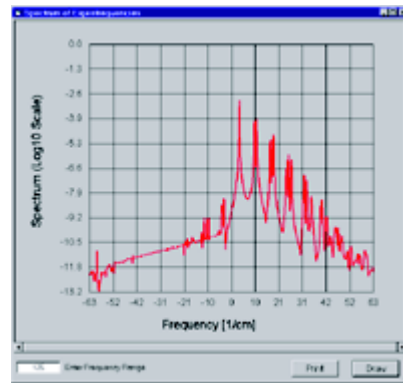

Spectrum of transverse eigenfrequencies

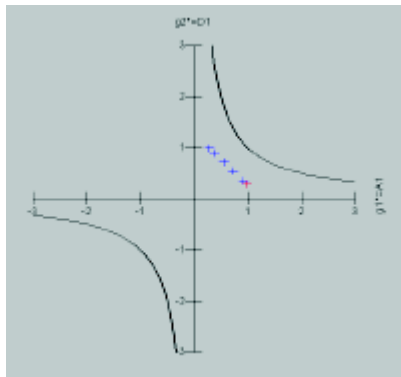

Stability diagram

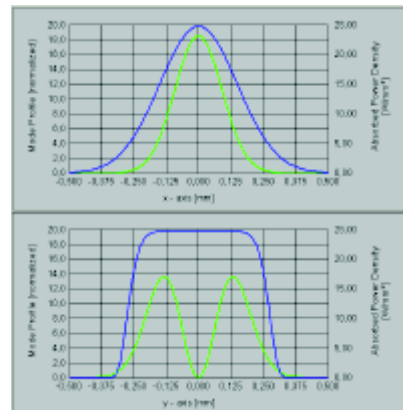

Overlap of laser modes and pump beam

GHOLOGRAPHIC COMPANY

Jhawar Kunj, Near Bajrang Dal Mill, Kotri, Kota, Rajasthan, India – 324007

Email: golographics@mail.com; www.genuineholographics.com

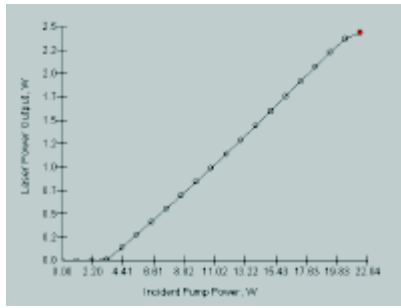

Laser power output

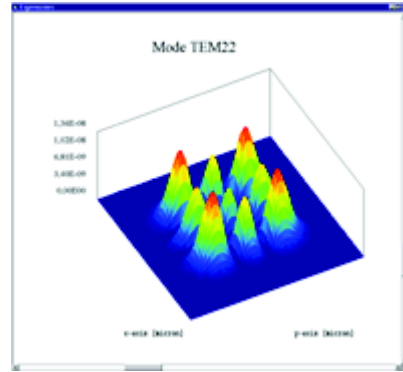

TEM₂₂ Eigenmode

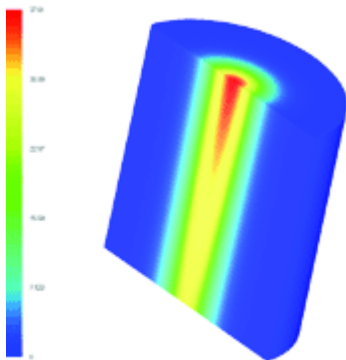

Heat load in a end pumped rod

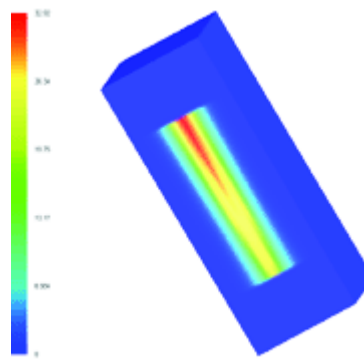

Heat load in a end pumped bloc with undoped end-capes

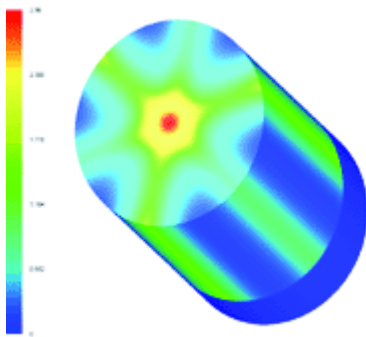

Heat load in a rod pumped from 3 sides

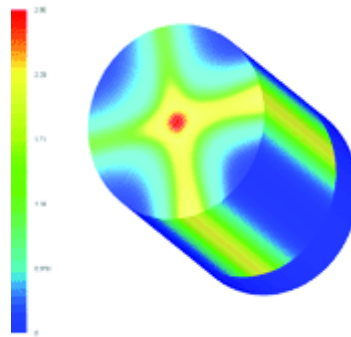

Heat load in a rod pumped from 2 sides

GHOLOGRAPHIC COMPANY

Jhawar Kunj, Near Bajrang Dal Mill, Kotri, Kota, Rajasthan, India – 324007

Email: gholographics@mail.com; www.genuineholographics.com

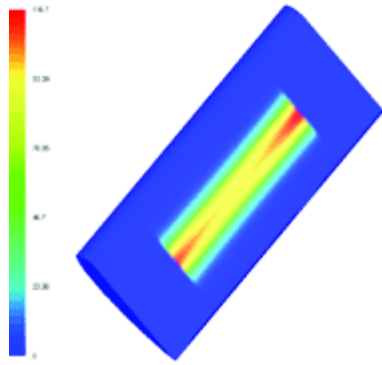

Dual end pumped rod with undoped endcapes

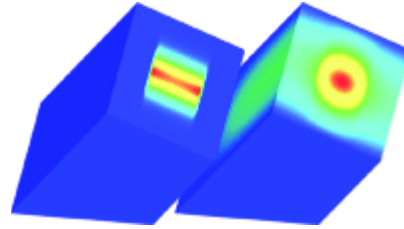

Absorbed pump power and temperature distribution in a sandwiched slab pumped from two sides

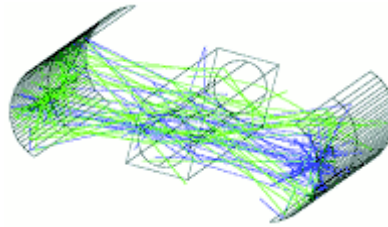

Flashlamp pumping ZEMAX

GHOLOGRAPHIC COMPANY

Jhawar Kunj, Near Bajrang Dal Mill, Kotri, Kota, Rajasthan, India – 324007

Email: gholographics@mail.com; www.genuineholographics.com

TFCalc - Thin Films Coating Software

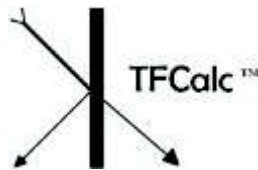

Capabilities

Up to 5000 layers on both sides of the substrate
Layers can be added manually or created with a stack formula, such as
 $(HL)^5$
 $1.2(HL)^5$
Layers may have a variable index
Layers may consist of mixtures of two materials
Layer thickness may be entered as physical or quarter-wave optical thickness
Layer thicknesses may be constrained
Thicknesses may be adjusted for angle
A layer may be replaced by an equivalent $(HLH)^p$ or $(LHL)^p$ stack
Layers may be grouped to preserve symmetry or to shift a sequence of layers
Rugate coatings can be simulated
Layers may consist of active and gain materials

Analysis

Compute reflectance, transmittance, absorptance, optical density, loss, phase shift,
psi, group delay (GD), group delay dispersion (GDD), TOD, and electric field intensity
Compute reflected or transmitted color (CIE and LAB)
Compute equivalent (Herpin) index of a sequence of layers
Compute the sensitivity of reflectance, transmittance, absorptance, optical density,
loss, phase shift, and color to normal manufacturing errors (thickness and index)
Compute the layer sensitivity
Compute cone-angle average (also called biconical) reflectance, transmittance,
absorptance, density, and loss with user-defined radiation distributions
Interactive analysis can be used to determine how changes to one or more parameters affect the performance
Animations can be created using the interactive analysis feature
Yield analysis allows the user to determine the manufacturability of a coating
Either the Muller or Abeles phase shift convention may be selected
Simulate the output of a light monitor
Compute admittance

GHOLOGRAPHIC COMPANY

Jhawar Kunj, Near Bajrang Dal Mill, Kotri, Kota, Rajasthan, India – 324007

Email: golographics@mail.com; www.genuineholographics.com

Optimization

Three local methods: Variable Metric, Gradient, and Simplex

Global Search may be used to find the best coating design

Needle optimization (with tunneling) may be used to synthesize unusual designs

Vary either thickness or index or both

Layer thickness can be constrained during optimization

Deviations are displayed during optimization

Index profile may be displayed during optimization

Flexible merit function

Optimize front and back layers simultaneously

Optimize group factors

Sensitivity may be optimized

Zero-thickness layers may be removed automatically during optimization

An illuminant and a detector function may be entered, making it possible to optimize a coating for specific environments

The product $R \cdot T$ can be optimized

Performance from both sides of a coating can be optimized

Cone-angle average may be optimized

Ultra-fast quantities (GD, GDD, TOD) may be optimized

Automatic design of bandpass filters using the prototype method

User Interface

Easy-to-use, standard Windows user interface

Menus, dialogs, spreadsheet-like windows

Very easy to edit and recomputed

All calculations are done in 16-digit floating-point arithmetic

During optimization, TFCalc calculates up to 500,000 layers/second on top-of-the-line computers

GHOLOGRAPHIC COMPANY

Jhawar Kunj, Near Bajrang Dal Mill, Kotri, Kota, Rajasthan, India – 324007

Email: golographics@mail.com; www.genuineholographics.com

Optical Design Consultancy

Gholographic Company has extensive experience with nearly every kind of optical system, including instrumentation, astronomical, illumination, night-vision, infrared, eyepieces, Architectural Lighting, Automotive, medical, solar industry and more. Let our expertise solve your design needs quickly and efficiently.

- Prototype development
- Detailed optical system design
- Tolerance budgeting
- Performance analysis, including Polarization, diffraction, scattering.
- Generate user Defined surface and Macros.
- Provide manufacturing facility for final design.

Think of us as part of your Optical Design team. .

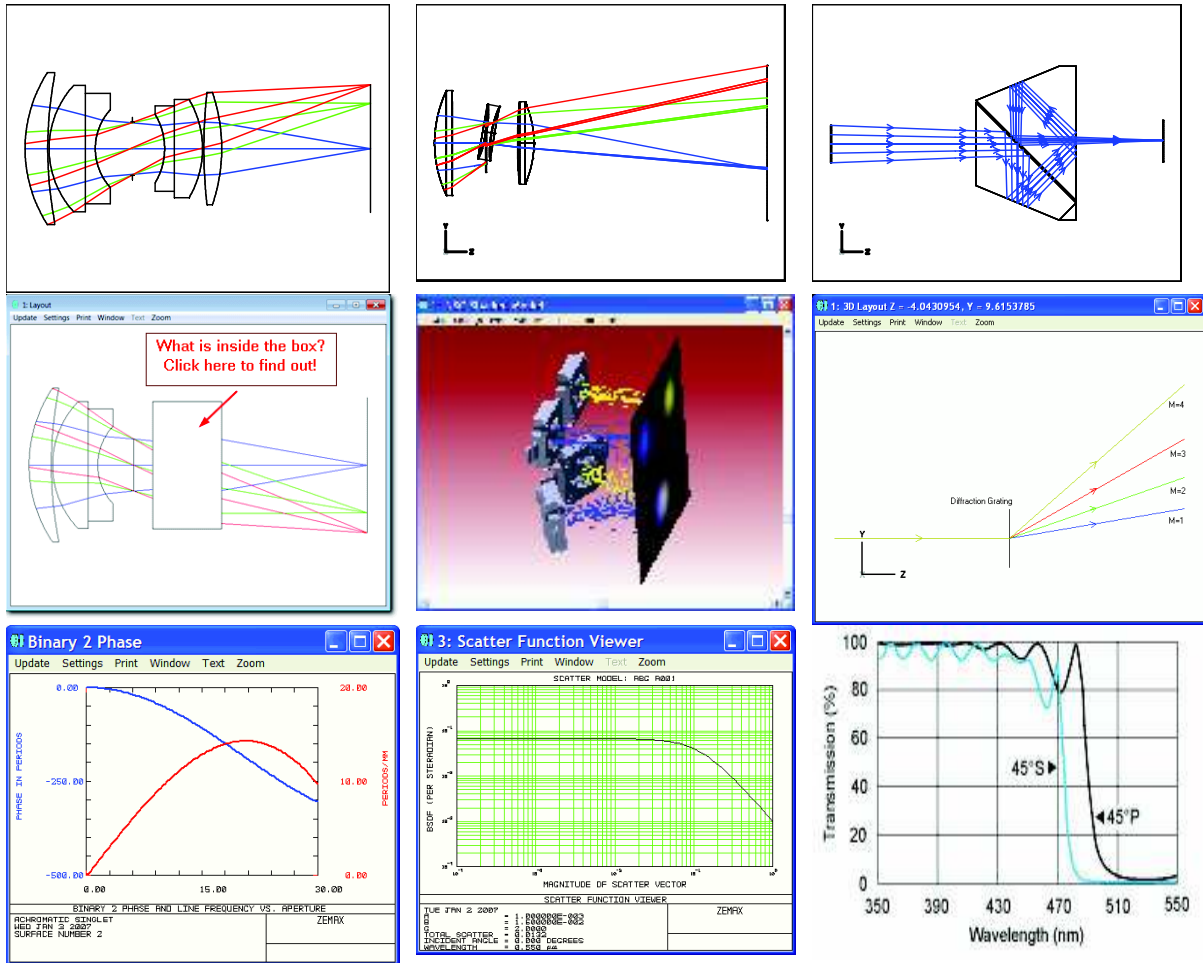

GHOLOGRAPHIC COMPANY

Jhawar Kunj, Near Bajrang Dal Mill, Kotri, Kota, Rajasthan, India – 324007

Email: gholographics@mail.com; www.genuineholographics.com

Optical Design Training

Gholographic Company organize training twice a year in field of optics, laser, LEDs, Projector, illumination system such as traffic light, LCD back lightning, image simulation, laser marking/cutting system, ocular lenses, telescope design etc.

we already conducted 3 Public Training Delhi, Bangalore and Ahmedabad and 1 Private Training at IIT Delhi.

As apart from Public course, we come up with **Customized or Private course**. Some company has more than 2 users of ZEMAX; to sent all the employee and afford for accommodation and air fares, we come up with Customized Solution. In this Customized course, Syllabus is mutual decided by User. Its only company application oriented.

Customized course is not user Limited; any number of employee from same company can utilize benefit of Training.

Frequently Asked Question (FAQ):

This course is for new user who only knows little about Optics/Illumination System Designing. We like to answer some general question which everyone likes to know.

a) ZEMAX is only for lens design?

No it is not only for lens design. ZEMAX is very well used in designing of Illumination & Imaging System.

b) In term of Knowledge benefit; what attendee gets in last?

Having Hand-On Experience on Designing Optical Component for machinery and Research Application. ZEMAX – Optical Design Software use all three days to analyze system performance.

c) Who can attend course?

Student, Researcher, Technician, Engineer and person who is interested to learn more on designing system by using software which save effort, time and cost.

d) Basic Knowledge of Optics needed?

No, Even mechanical & Electrical Engineer also uses ZEMAX very easily.

e) How long is this course?

Its Three day course to make familiar and explain easiest approach to do design. If need deep detail; we also offer 5 days course.

f) What is Benefit by this course?

GHOLOGRAPHIC COMPANY

Jhawar Kunj, Near Bajrang Dal Mill, Kotri, Kota, Rajasthan, India – 324007

Email: gholographics@mail.com; www.genuineholographics.com

This course will cover topic related to latest emerging technology such as LED, SOLAR, Infrared Imaging (Camera used to detect H1N1), Micro Lens Design, Laser Industry (Marking and Cutting) and Ophthalmic Industry.

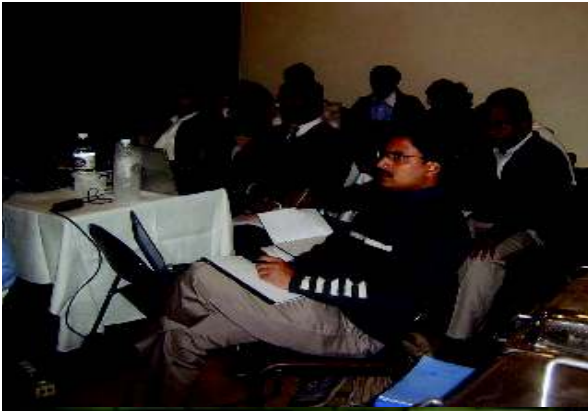

GHOLOGRAPHIC COMPANY

Jhawar Kunj, Near Bajrang Dal Mill, Kotri, Kota, Rajasthan, India – 324007

Email: golographics@mail.com; www.genuineholographics.com

Optical Design Books:

We can provide following books to support in design to our customer. Please find below best books for optics and lens design.

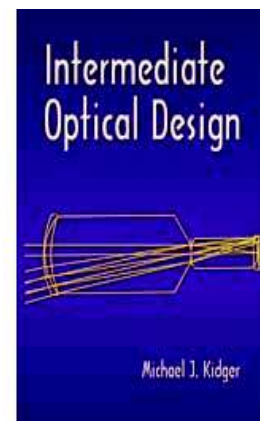
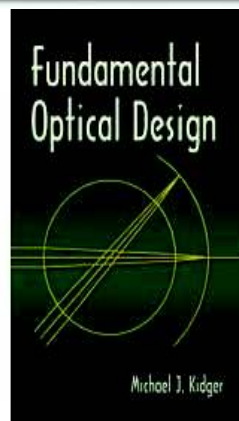
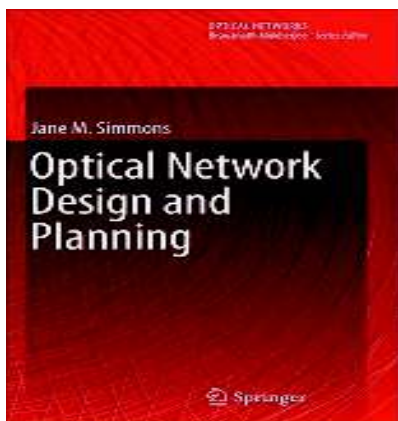
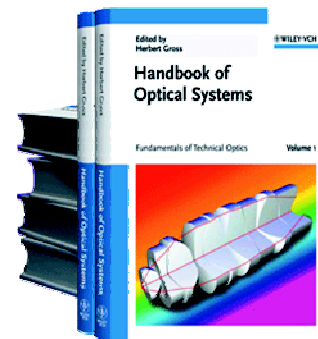
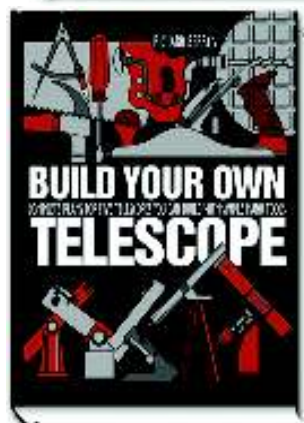
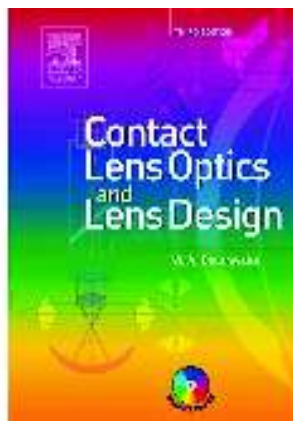
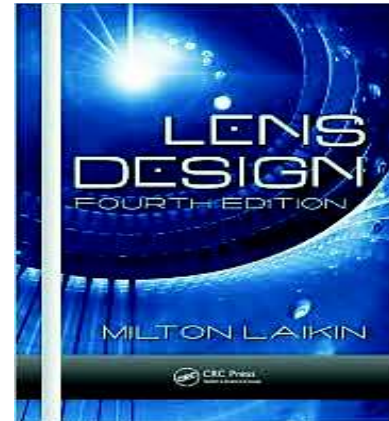
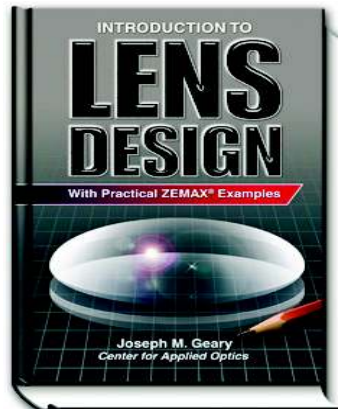
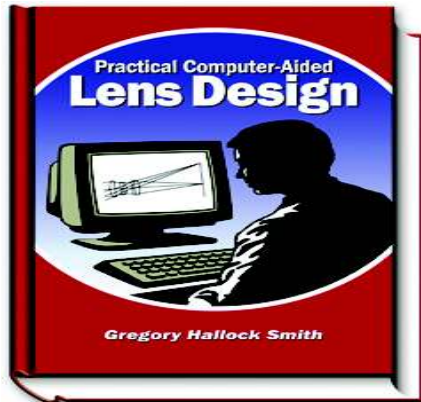

GHOLOGRAPHIC COMPANY

Jhawar Kunj, Near Bajrang Dal Mill, Kotri, Kota, Rajasthan, India – 324007

Email: gholographics@mail.com; www.genuineholographics.com

Holographic Plate

Holographic plates have emulsion coated on glass plates with thickness of approximately 2.4 mm. Customized larger sizes also available.

Holographic film have emulsion coated on triacetate substrate with thickness of 180 microns.

Emulsion Description

- | | |
|----------------|--|
| PFG-01 | Fine-grained red sensitive holographic plates and film designed for transmission or reflection hologram recording. Average grain size is 40 nm, resolving power more than 3000 lines/mm, spectral sensitivity range 600-680 nm (including 633 nm, 647 nm), and emulsion thickness 7-8 um |
| PFG-03M | Ultra fine-grained red sensitive plates and film specially designed for reflection hologram recording. Average grain size is 8-12 nm, resolving power more than 5000 lines/mm, spectral sensitivity range includes 633 nm, 647 nm, and emulsion thickness 6-7 um. |
| PFG-03C | Ultra Fine-grained panchromatic (full color) holographic plates designed for color reflection hologram recording. Average grain size is 8 nm, resolving power more than 5000 lines/mm, spectral sensitivity range up to 700 nm (457 nm, 514 nm, 633 nm), and emulsion thickness 9-10 um. |
| PFG-04 | Long-life Dichromated Gelatin holographic plates designed for phase reflection hologram recording with blue or green laser. Grainless emulsion with resolving power greater than 5000 lines/mm, spectral sensitivity range up to 514 nm (457 nm, 488 nm, 514 nm), and emulsion thickness 16-17 um. |
| VRP/-M | Fine-grained green sensitive holographic plates and film designed for reflection or transmission hologram recording. Average grain sizes 35-40 nm, resolving power is more than 3000 lines/mm, spectral sensitivity range includes 488 nm, 514 nm, 526 nm, and 532 nm, and emulsion thickness 6-7 um |

GHOLOGRAPHIC COMPANY

Jhawar Kunj, Near Bajrang Dal Mill, Kotri, Kota, Rajasthan, India – 324007

Email: gholographics@mail.com; www.genuineholographics.com

Sizes Available

Holographic Plates

mm	406 x 609	300 x 406	180 x 240	102 x 127	63 x 63
inches	16" x 24"	12" x 16"	8" x 10"	4" x 5"	2.5" x 2.5"
PFG-01		✓	✓	✓	✓
PFG-03		✓	✓	✓	✓
PFG-03C		✓		✓	✓
PFG-04		✓	✓	✓	✓
VRP-M	✓	✓	✓	✓	✓

Holographic Film

mm	1000 x 10000	350 x 1000	102 x 2000	350 x 2000	300 x 406	180 x 240	102 x 127
inches / feet	39" x 33'	14" x 33'	4" x 65'	14" x 33'	12" x 16"	8" x 10"	4" x 5"
PFG-01	✓	✓	✓	✓	✓	✓	✓
PFG-03							
PFG-03C	✓	✓					
PFG-04							
VRP-M		✓	✓	✓	✓		✓

GHOLOGRAPHIC COMPANY

Jhawar Kunj, Near Bajrang Dal Mill, Kotri, Kota, Rajasthan, India – 324007

Email: gholographics@mail.com; www.genuineholographics.com

Hologram Developers

Avoid the hassle and expense of mixing your own chemicals. JD processing kits are the most widely used pre-packaged chemical developers for holographers today. Kits include all chemicals and instructions for processing holograms. Just add water, and be done processing a hologram in as little as 3 minutes. Each kit processes up to thirty 2.5" x 2.5" plates, twelve 4"x5" plates, or twenty sheets of 4" x 5" film.

Item#	Product	Details
JD2	JD-2 Processing Kit	Use with PFG-01 and VRP-M emulsions. Appropriate for high school and university classrooms (contains potassium dichromate).
JD3	JD-3 Processing Kit	Use with PFG-01 emulsions. Appropriate for middle school classrooms (contains copper sulfate instead of potassium dichromate).
JD4	JD-4 Processing Kit	Use with PFG-03M and BB-640 emulsions. Appropriate for middle schools to university classrooms (contains copper sulfate instead of potassium dichromate).

GHOLOGRAPHIC COMPANY

Jhawar Kunj, Near Bajrang Dal Mill, Kotri, Kota, Rajasthan, India – 324007

Email: gholographics@mail.com; www.genuineholographics.com

Holography Kit

We offer three holography kits, each of which let you make many types of holograms, from basic reflection (viewable with white light) and transmission holograms (viewable with laser) to more advanced multiple-image recordings and interferometry. The kits also include a booklet that help you understand how holograms actually work.

All kits include the same holographic recording materials used by most leading holographic artists and professionals today, and can provide high-level consistency, luminance, and clarity.

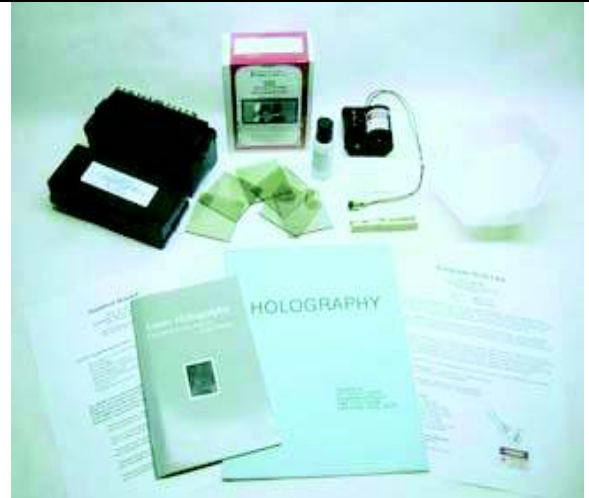

	Standard HOLOKIT™ laser holography kit	Student HOLOKIT™ laser holography kit	Budget HOLOKIT™ laser holography kit
Description	For educators and individuals, this kit makes 30 holograms on glass plates.	For students and individuals, this kit makes 12 holograms on glass plates.	For budget-conscious individuals, this kit makes 10 holograms on film sheets.
Step-by-Step Instructions <i>Detailed explanations, tips, pictures, etc..</i>	✓	✓	✓
Professional Recording Material <i>High resolution, red-sensitive.</i>	Thirty (30) PFG-03M plates 2.5"x2.5" (63x63mm)	Twelve (12) PFG-03M plates 2.5"x2.5" (63x63mm)	Ten (10) PFG-01 film sheets 4"x5" (102x127mm)
Holography Diode Laser <i>Class IIIa, 3-4mW, highly stabilized.</i>	✓	✓	✓
Chemical Processing Kit <i>Pre-measured. Just add water.</i>	JD-4	JD-4	JD-2
PhotoFlo (30ml) <i>Wetting agent for making better holograms.</i>	✓	✓	✓
"Experiments You Can Do" <i>Booklet by Dr. T. Jeong teaches you how to make seven different kinds of holograms.</i>	✓	✓	✓
"HOLOGRAPHY" <i>Booklet by Dr. T. Jeong explains how holograms work using basic physics.</i>	✓	✓	✓
Developer Trays (3) <i>Approx. 3.5" x 3.5", plastic, reusable.</i>	✓	✓	
Film Holder <i>Two glass plates with metal clamps.</i>	Not needed	Not needed	✓
Accessories <i>Battery holder and clothespin mount for laser.</i>	✓	✓	✓
Free Technical Support	✓	✓	✓

GHOLOGRAPHIC COMPANY

Jhawar Kunj, Near Bajrang Dal Mill, Kotri, Kota, Rajasthan, India – 324007

Email: golographics@mail.com; www.genuineholographics.com

ScatterScope Overview

ScatterScope3D measures and records sample scatter in about a 40 degree area surrounding the reflected (or transmitted) specular beam. Results are displayed as user selectable profiles, color related intensity plots or as a three dimensional simulation in BSDF units compatible with SEMI Standards. An increasing number of analysis tools are being developed to handle the data. The system is powered through the USB port of the provided laptop.



ScatterScope3D Specifications

Mechanical

Weight 10 lbs
Dimensions w/o computer 11" L, 8.25" W, 6" H

Electrical Requirements

Computer 120VAC typical
System USB port on computer

Optical

Measurement Lasers 635 nm wavelength, less than 1.0 mW power
Viewing LED Allows reflective sample area to be viewed.

Software

ScatterMaster Compatible with XP, Vista and Windows 7.

Measurement and Analysis

Scan Area Approximately 4.5 mm diameter circle.
Measurement Time Approximately 15 seconds
Analysis Reports are generated automatically. Data can be saved in Excel format

Data Storage

Numerical Results Stored in Excel Files
Pictures Stored in jpg, tif format

Michelson Interferometer

It is Lab Experiment instrument for college and universities. To Determine and observe optical Interference & Determine the wavelength of light source.



GHOLOGRAPHIC COMPANY

Jhawar Kunj, Near Bajrang Dal Mill, Kotri, Kota, Rajasthan, India – 324007

Email: gholographics@mail.com; www.genuineholographics.com

Refractometer

Gholographic Comany, is a professional company which sells all kinds of refractometers, mainly including Hand Held Refractometers, Digital refractometers, Abbe refractometers, Gem refractometers and Digital Gem Refractometers. Our Products are not only facing to domestic market, but also to overseas market, especially Europe, Australia and America. Through several years of exporting refractometers to many countries, we have earned good reputation in this line. We insist on developing new type of refractometers to meet the satisfaction of our customers.

Digital Refractometer



Digital Refractomete...



Digital Refractomete...



Digital Refractomete...



Digital Refractomete...

Handheld Refractometer



Hand Held Refractome...



Hand Held Refractome...



Hand Held Refractome...



Hand Held Refractome...



Hand Held Refractome...



Hand Held Refractome...



Hand Held Refractome...



Hand Held Refractome...



Hand Held Refractome...

GHOLOGRAPHIC COMPANY

Jhawar Kunj, Near Bajrang Dal Mill, Kotri, Kota, Rajasthan, India – 324007

Email: gholographics@mail.com; www.genuineholographics.com

Abbe's Refractometer



ABBE refractometer

Gem Refractometer



Gem refractometer RI...



Gem refractometer



Digital Gem Refracto...



Traditional Gem Refr...

GHOLOGRAPHIC COMPANY

Jhawar Kunj, Near Bajrang Dal Mill, Kotri, Kota, Rajasthan, India – 324007

Email: gholographics@mail.com; www.genuineholographics.com

GHOLOGRAPHIC COMPANY

Jhawar Kunj, Near Bajrang Dal Mill, Kotri, Kota, Rajasthan, India – 324007

Email: gholographics@mail.com; www.genuineholographics.com